

**OMICRON  
21300-10(H) 316L  
PN16**

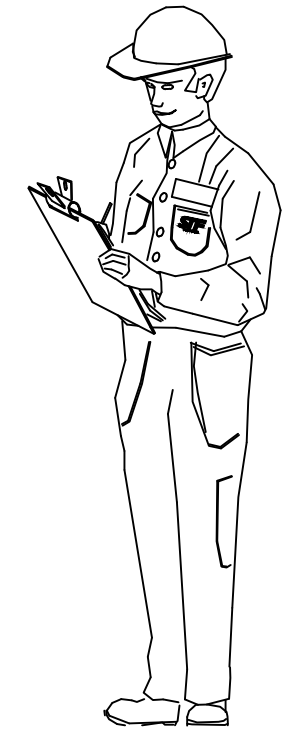

ITEM	LINE	CONNECTION
A	RAW WATER INLET	6" 150# ANSI
B	FILTERED WATER OUTLET	6" 150# ANSI
C	BACKWASH OUTLET	2" 150# ANSI

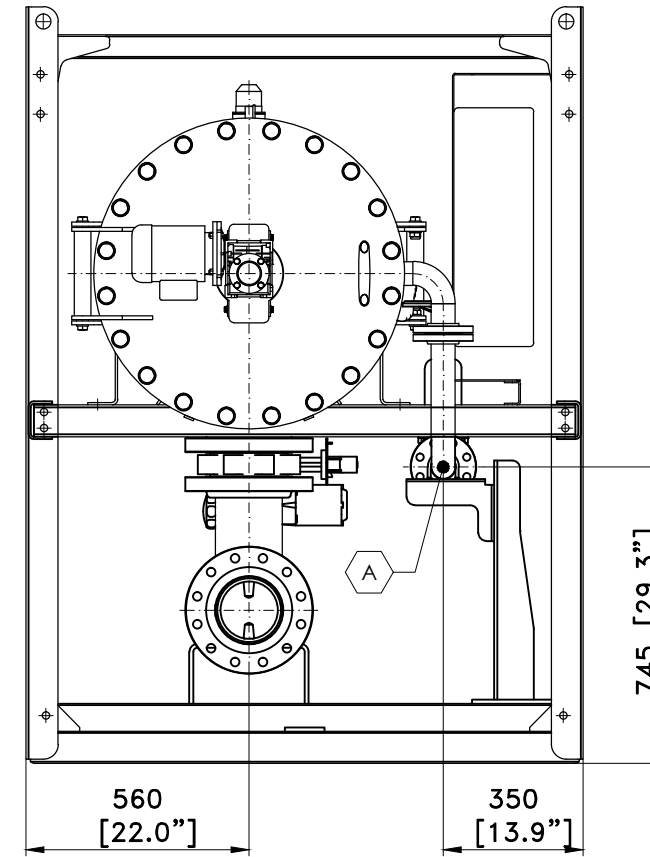
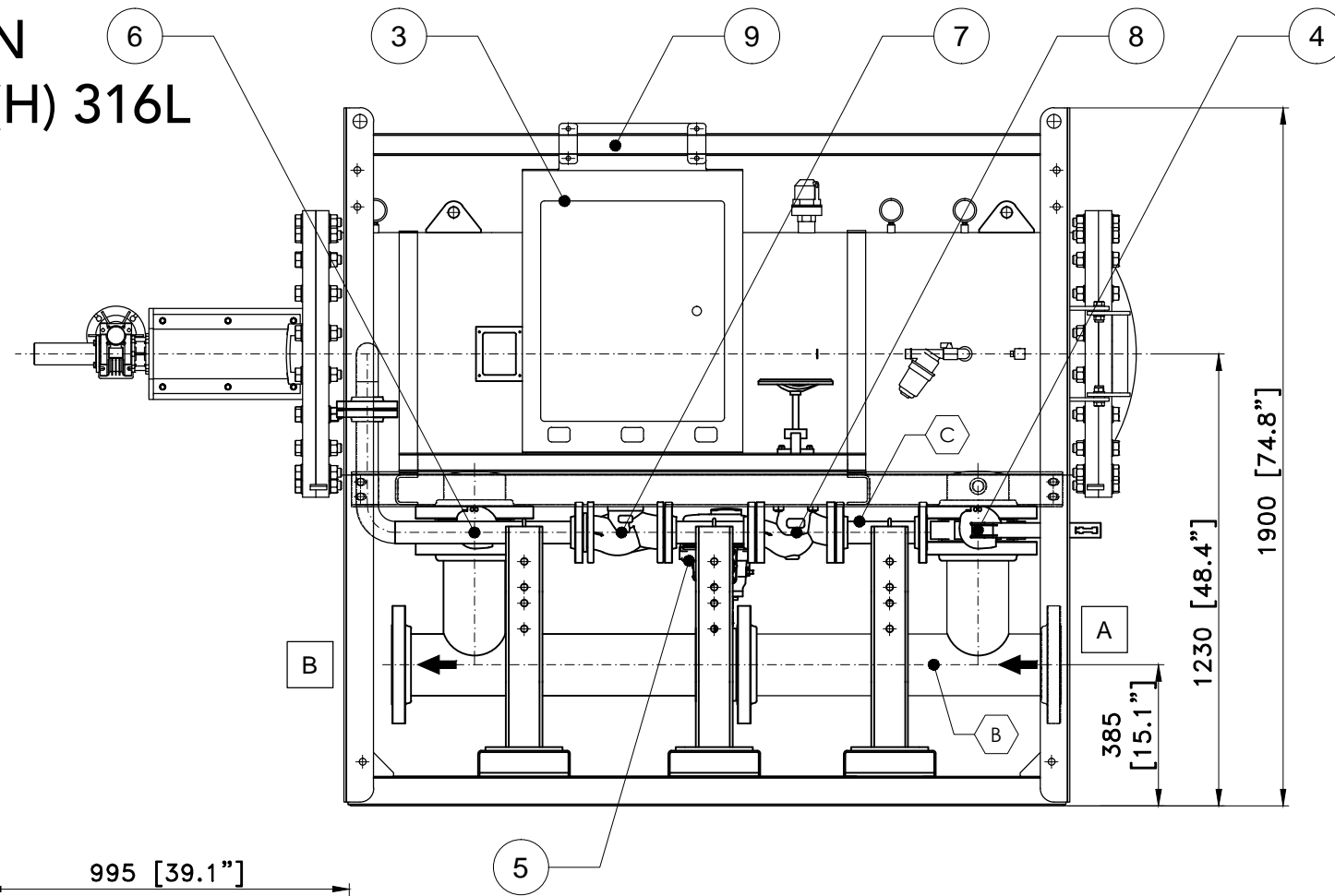
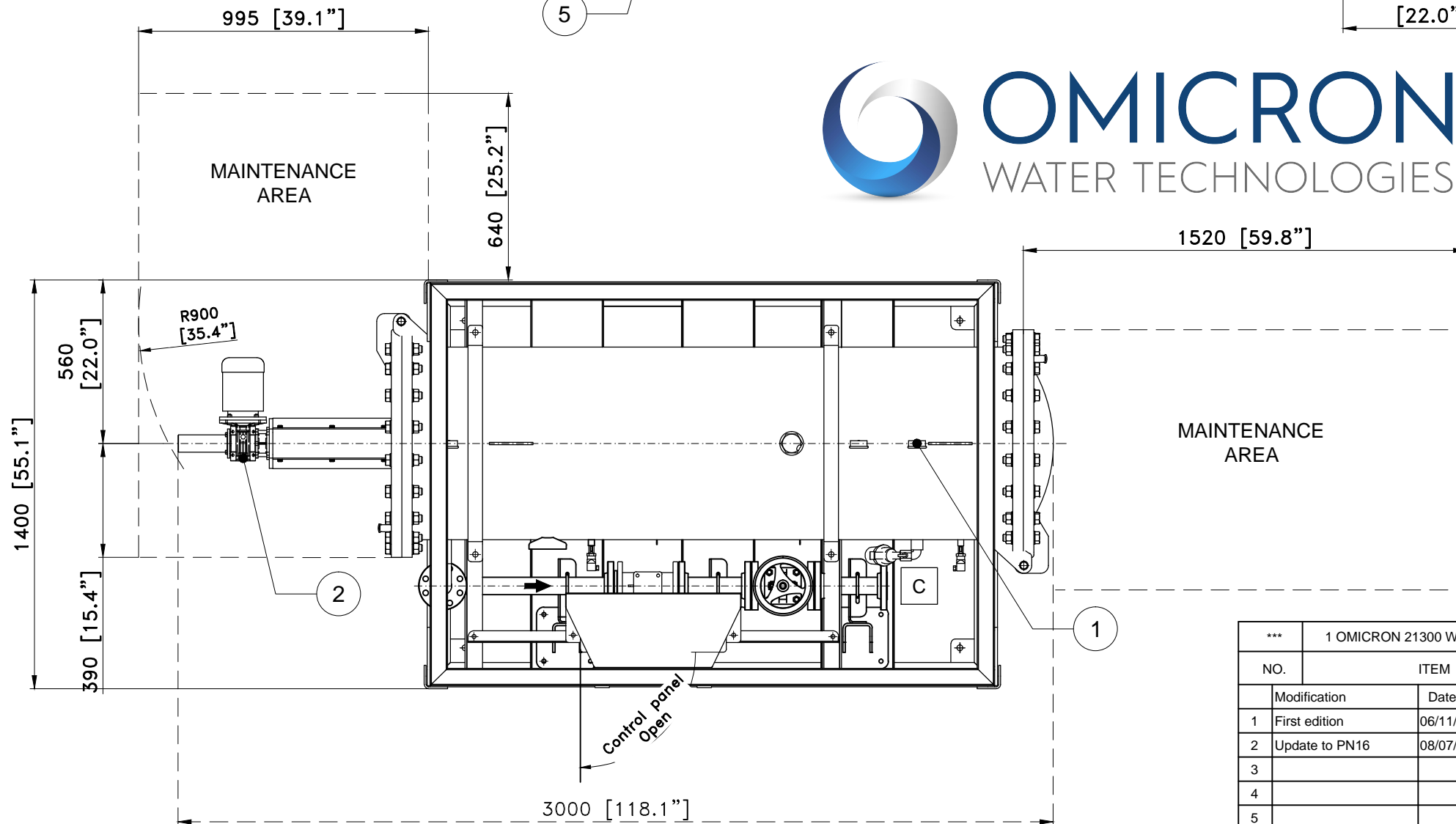

ITEM	DESIGNATION	QTY	MATERIAL	OBSERVATIONS
1	AUTOMATIC FILTER: FMA-2014 WITH INLET / OULET NOZZLES 6"-150lbs	1	AISI-316L	
2	ELECTRIC MOTOR	1	...	
3	CONTROL PANEL DIMENSIONS: 600 x 500 x 200	1	...	
4	WAFER BUTTERFLY VALVE 6" - 150Lbs	1	IRON CAST	RAW WATER INLET
5	WAFER BUTTERFLY VALVE 6" - 150Lbs	1	IRON CAST	BY-PASS
6	WAFER BUTTERFLY VALVE 6" - 150Lbs	1	IRON CAST	FILTERED WATER OUTLET
7	BACKWASH VALVE 2" - FLANGED L = 210	1	IRON CAST	BACKWASH OUTLET
8	GATE VALVE 2" - FLANGED L = 216	1	IRON CAST	BACKWASH OUTLET
9	SKID	1	S-275-JR	

NO.	ITEM	QUANTITY	MATERIAL	OBSERVATIONS
...	1 OMICRON 21300 WITH MANIFOLD	1	STAINLESS STEEL	...
1	Modification	Date	Name	Sign.
1	First edition	06/11/18	J.P.R.	
2	Update to PN16	08/07/19	J.P.R.	
3	DESCRIPTION			
4	OMICRON 21300-10(H) PN16			
5	Work Order	N° Drawing	Projection	
6	65006	19.65006.00.00		

Scale	Format	Date	Name	Signed
1:1	A3	29/05/19	J.P.R.	
		08/07/19	J.P.R.	

