

mm [in]

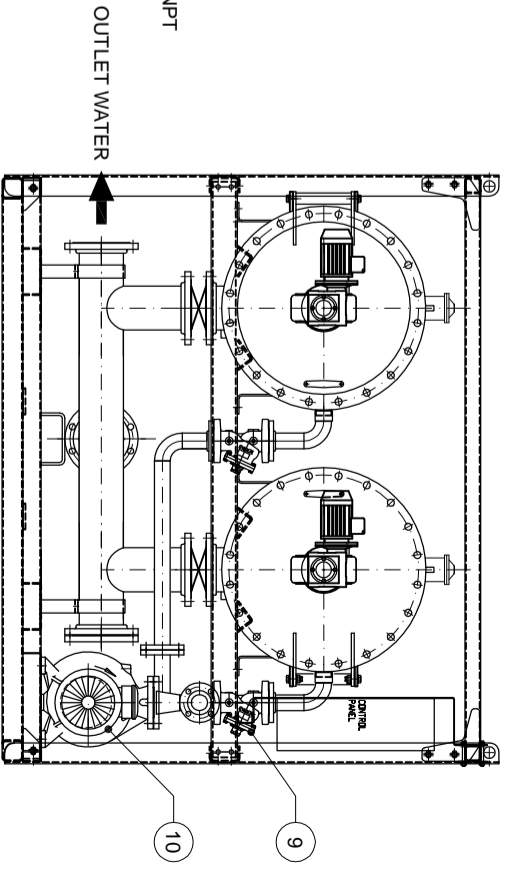

OMICRON TWIN 21300 (H) SKID

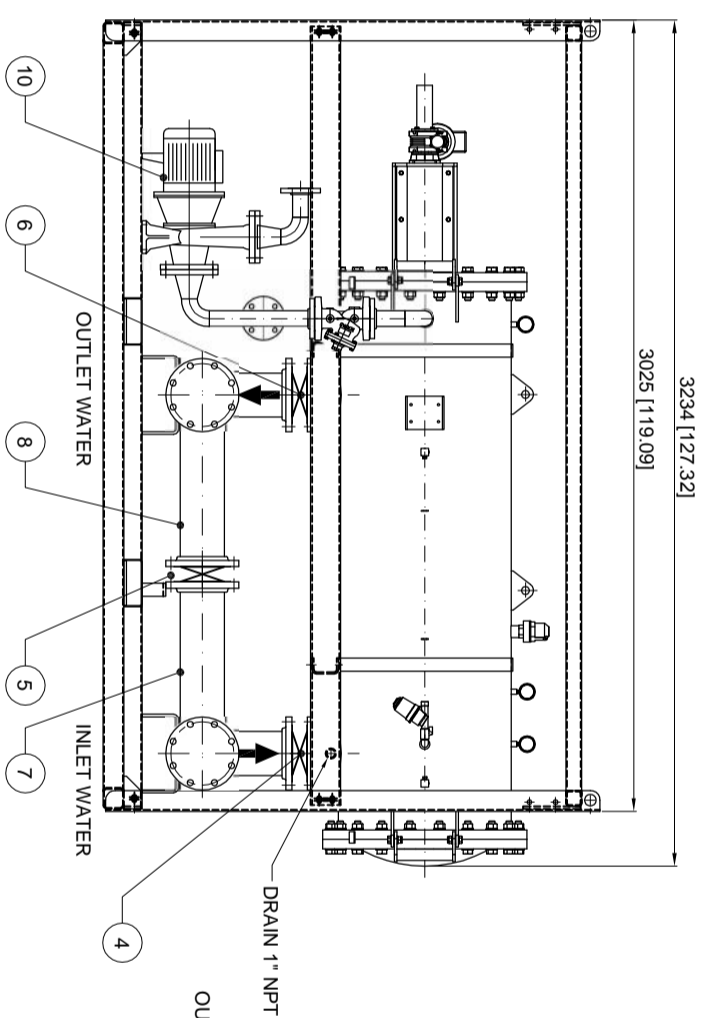
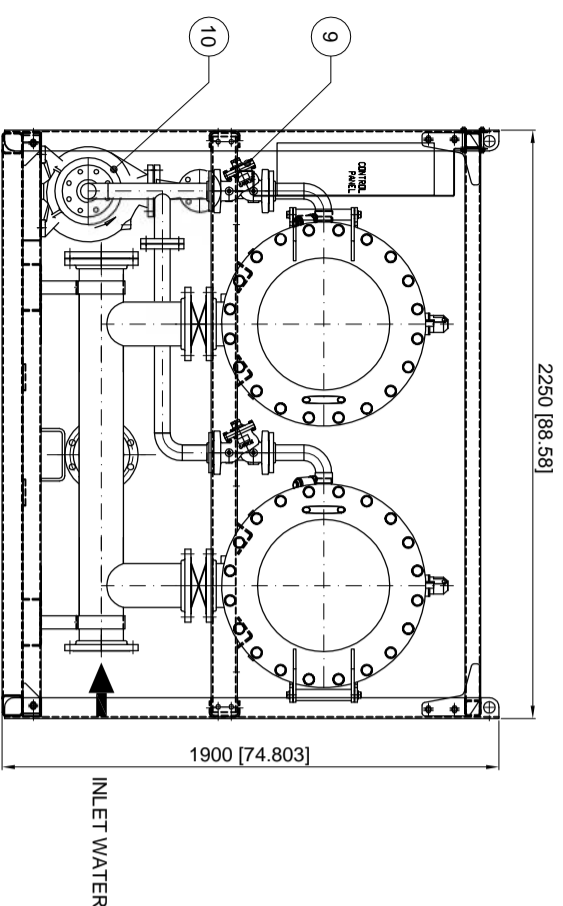

NO.	ITEM	QTY.
1	SCREEN FILTER TYPE FMA-2014	2
2	ELECTRIC ENGINE	2
3	CONTROL PANEL	1
4	MANUAL BUTTERFLY VALVE 6"	2
5	MOTORIZED VALVE 6" - BY-PASS	1
6	MANUAL BUTTERFLY VALVE 6"	2
7	RAW WATER INLET 6"	1
8	FILTERED WATER OUTLET 6"	1
9	BACKWASH WATER OUTLET 2"	2
10	PUMP BACKWASH OUTLET	1

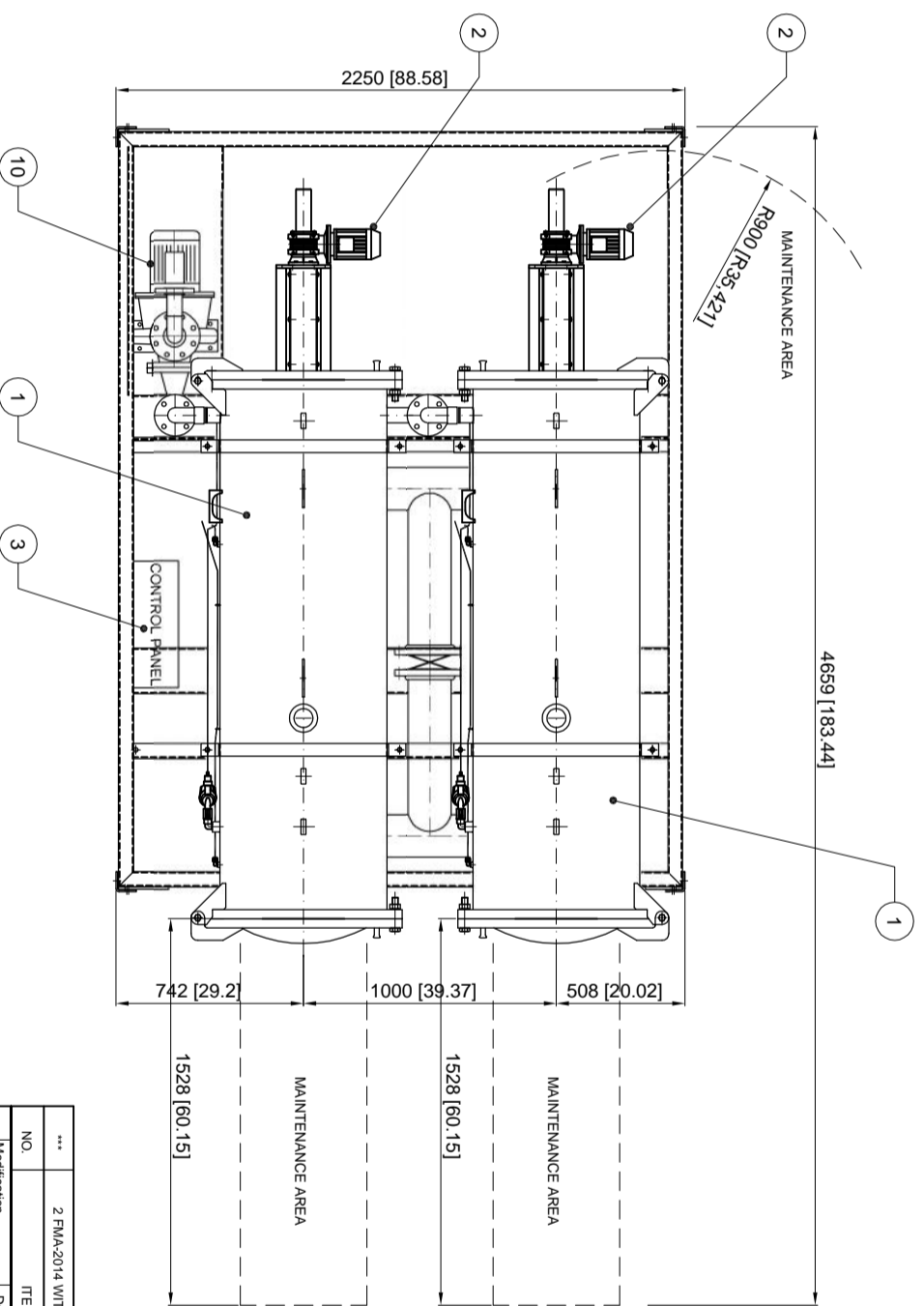

NO.	2 FMA-2014 WITH MANIFOLDS	QUANTITY	1	MATERIAL	STAINLESS STEEL	OBSERVATIONS	...
Modification	Date	Name	Sign.	CLIENT	OMICRON WATER TECHNOLOGIES	Scale	1:20
0 FIRST EDITION	24/03/17	M.A.C.		REFERENCE	...	Format	A2
1				DESCRIPTION	SKID 2 x OMICRON 21300 -10 (H)	Drawn	20/03/17
2				Work Order#	17.00000.00.00	Reviewed	
3						Approved	
4							
5							

